

101

Register No.:

October 2023

Time - Three hours
(Maximum Marks: 100)

- [N.B. 1. Answer all questions under Part-A. Each question carries 3 marks.
2. Answer all the questions either (A) or (B) in Part-B. Each question carries 14 marks.]

PART - A

1. Define force.
2. What is elastic limit?
3. List out types of support.
4. Define bending moment.
5. Define centroid.
6. State parallel axis theorem.
7. What is meant by simple bending? Write down the bending equation.
8. A shaft rotates at 60 rpm produces 20 kW. Find the torque of the shaft.
9. State statically determinate and statically indeterminate frames.
10. What is space diagram?

PART - B

11. (a) A prismatic bar of cross section 30 mmx20 mm and 600mm long elongates by 3mm under a pull of 45 kN. Calculate Young's modulus and decrease in width and thickness. The Poisson's ratio is 0.25.

(Or)

[Turn over.....

- (b) (i) Determine the Poisson's ratio and bulk modulus of material for which Young's modulus is $1.2 \times 10^5 \text{ N/mm}^2$ and modulus of rigidity is $4.5 \times 10^4 \text{ N/mm}^2$.(7)
(ii) Derive the expression for total elongation of a bar due to self weight.(7)

12. (a) Construct the Shear force and bending moment diagram for the Cantilever beam shown in fig. and write the values at salient points.

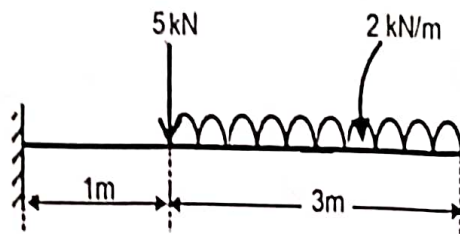

(Or)

- (b) A simply supported beam of 7m span carries a point load of 60kN at 2m from the left support and an UDL of 20kN/m for a length of 3.5m from the right support. Draw the SFD and BMD.

13. (a) (i) Write the expression for the centroids of semicircular and quadrant sections.(7)
(ii) Locate the centroid of an angle section as shown in figure.(7)

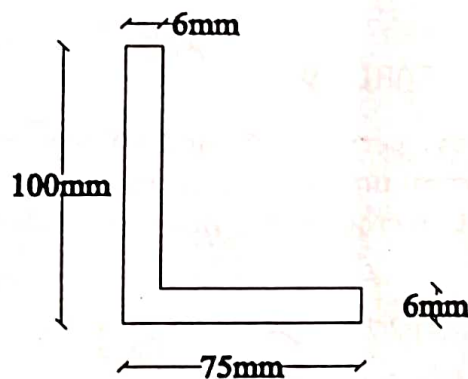

(Or)

- (b) Calculate the moment of inertia of the I-Section about XX and YY axes having the following details:
Top flange: 150mm X 15mm, Web: 220mm X 15mm,
Bottom flange: 150mm X 15 mm.

14. (a) A simply supported timber beam is 6m long. It carries an UDL of 15 kN/m over the entire span and a point load of 10kN at mid span. The stress in beam is not to exceed 8N/mm². Design a suitable section by assuming depth as twice the width.

(Or)

- (b) Calculate the dia. of the shaft to transmit 45kW at 120rpm. If the maximum permissible torque is likely to exceed the mean by 30%, calculate the angle of twist for a length of 2m. Take the value of G as 80kN/mm².

15. (a) Determine the magnitude and nature of forces in the members of truss shown in figure by method of joints.

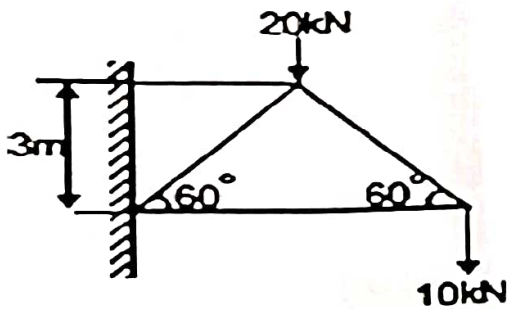

(Or)

- (b) Determine the magnitude and nature of forces in the members of truss shown in figure by Graphical method.

